

# USER MANUAL

## High Resolution IR Camera Series



The product image may differ from the actual product.  
Please read the instructions thoroughly before using the product.

### OVERVIEW

This high resolution camera contains day and night feature, built-in 35 IR LEDs and IP67 standard approved waterproof outdoor housing. Besides, it is very easy to install.

### FEATURES

1. High resolution of 520 TV Lines
2. Excellent image quality
3. High sensitivity in the dark environment, 0.1 Lux / F2.0, 0 Lux (IR ON)
4. Day and night features for 24-hour surveillance
5. IR LED effective range reaches up to 25 meters
6. IP67, suitable for outdoor use

### PACKAGE CONTENT

- IR camera with a power and video cable \* 1
- Bracket \* 1
- Accessory pack x 1
- User Manual \* 1

### SPECIFICATIONS\*

MODEL	IR Camera	
Pick-up Element	1/3" H.R. Color CCD image sensor	
Number of Pixels	768(H) x 494(V) <NTSC> / 752(H) x 582(V) <PAL>	
Resolution	520TVL	
Min. Illumination	0.1 Lux / F2.0, 0 Lux (IR ON)	0.05 Lux / F1.4, 0 Lux (IR ON)
IR LED	35 units	
IR Effective Range	25 Meters	
S/N Ratio	More than 48dB (AGC OFF)	
Electronic Shutter	1/60 (1/50) to 1/100,000 sec.	
Lens	f3.6mm / F2.0	f6.0mm / F1.4
Lens Angle	92.6°	54°
White Balance	ATW	
AGC	Auto	
IRIS Mode	AES	
IP Rating	IP67	
Video Output	1.0 Vp-p composite, 75Ω	
Operating Temperature	-20°C~40°C	
Power Source (±10%)	DC12V	
Current Consumption (±10%)	70mA (IR OFF), 400mA (IR ON)	
Gross Weight (g)	430	
Dimensions (mm)**	142(H) x 75 (Φ)	

\* The specifications are subject to change without notice.

\*\* Dimensional Tolerance: ± 5mm

## INSTALLATIONS

1. Use the supplied three screws to attach the bracket to wall. Drill a hole in advance on the proper position of the wall for the Power and Video Cable to pass through later.
2. Remove the Joint Lock from the bracket by turning it counterclockwise. Then, screw the Joint Lock to the backside of the camera (turn clockwise)\*.

**NOTE: There are two screw holes on the backside of the camera. Please choose the proper one which best suits your installation environment.**

3. Screw the camera with the Joint Lock connected to the bracket. After that, secure the Joint Lock to fix. Then, pass the Power and Video Cable through the hole drilled in Step 1 to hide it.

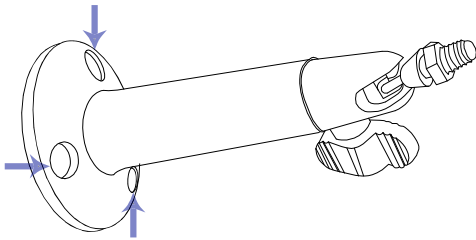

Figure 1

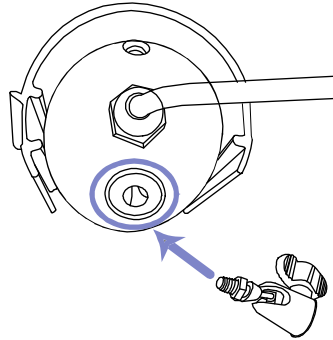

Figure 2

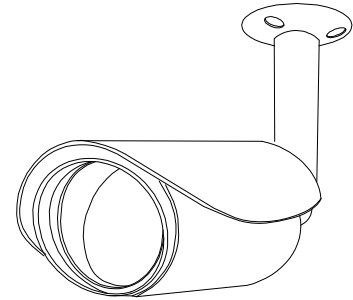

Figure 3

## CONNECTION

1. DC12V Input Terminal  
Connect the power terminal of the camera to a DC 12V regulated power supply.

**NOTE: Please use the correct power adaptor, DC12V (regulated), to operate this unit. The power tolerance of this unit is DC12V  $\pm$  10%. Over maximum DC 12V power input will damage this unit.**

2. Video Output Connector (VIDEO OUT)  
Connect the camera video output and the monitor video input with 75 $\Omega$  coaxial cable.

**NOTE: To ensure the camera has sufficient protection against moisture, an extra waterproof measure, such as by using an insulating tape, must be used to cover the power and video connectors after connection.**



### CAUTION

**RISK OF ELECTRIC SHOCK**



#### CAUTION:

To reduce the risk of electric shock, do not expose this apparatus to rain or moisture.

Only operate this apparatus from the type of power source indicated on the label.

The company shall not be liable for any damages arising out of any improper use, even if we have been advised of the possibility of such damages.



The lightning flash with arrowhead symbol, within an equilateral triangle, is intended to alert the user to the presence of uninsulated "dangerous voltage" within the product's enclosure that may be of sufficient magnitude to constitute a risk of electric shock to persons.



This exclamation point within an equilateral triangle is intended to alert the user to the presence of important operating and maintenance (servicing) instructions in the literature accompanying the appliance.



#### ROHS Announcement

All lead-free products offered by the company comply with the requirements of the European law on the Restriction of Hazardous Substances (RoHS) directive, which means our manufacture processes and products are strictly "lead-free" and without the hazardous substances cited in the directive.



The crossed-out wheeled bin mark symbolizes that within the European Union the product must be collected separately at the product end-of-life. This applies to your product and any peripherals marked with this symbol. Do not dispose of these products as unsorted municipal waste.



#### CE Mark

This apparatus is manufactured to comply with the radio interference.

The company does not warrant that this manual will be uninterrupted or error-free. We reserve the right to revise or remove any content in this manual at any time.